

Technical Information

RFID-Lock 1905

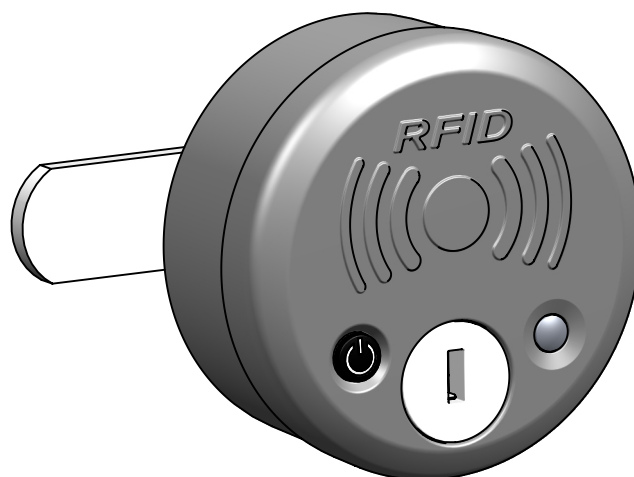

Product description / instructions for use	2
Standard mounting options	3
Recessed mounting options	4
Assembly / assembly sequence	5
Setting the direction of rotation	6
Battery change	7
Emergency opening using the service key	8
Order matrix cam	9
Order matrix lock	10
Operating and programming instructions	11
Master command sequences	12



WEEE-Reg.-No. DE 96481460

Product description

- + Closed RFID locking system 13.56 MHz (Mifare Ultralight)
- + Private and public applications
- + Read / Write System (occupancy detection / locker number)
- + NFC transponders in cards, tags or wristbands available
- + All transponders fast and flexibly programmable to master or user transponder
- + AUTO-OPEN TIMER available to avoid permanent reservations in public mode
- + LED and sound signals
- + Factory reset option
- + Can be retrofitted (standard fastening 16x19)
- + Battery operated and independent of the mains (stand alone)
- + Mechanical service cylinder for emergency opening
- + Maintenance and environmentally friendly LOW ENERGY SYSTEM
(approx. 80,000 locking cycles with a single commercially available standard battery) *
- + Battery: 1x 1.5V AA (standard alkaline manganese cell)
- + Changing the battery quickly and easily using the service key from the front when the door is closed, without additional tools and while retaining all settings.
- + Additional fastening options for wooden, HPL and glass doors
- + Control panel can be removed using a service key, e.g. for changing batteries, programming or for locker transport
- + Direction of rotation R / L can be selected for left or right hinged doors
- + Extensive selection of cams
- + Ready-to-install delivery condition including cam, fastening material and battery

* Depending on the operating mode, battery quality and without taking into account any that have occurred over the years self-discharge

Usage note

This product is for indoor use in a temperature range of 5-50C ° provided. Protect it from environmental influences such as water, moisture, Heat, frost and dirt.

Further information on: www.wf-locks.de

Standard mounting options

1. Fastening in steel doors with a 16x19 hole pattern

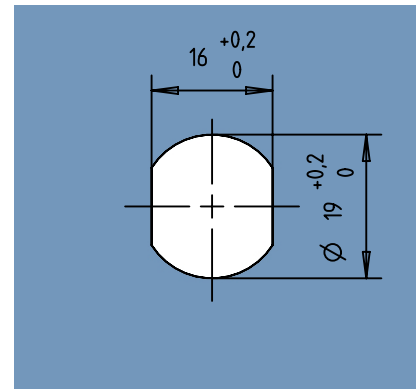
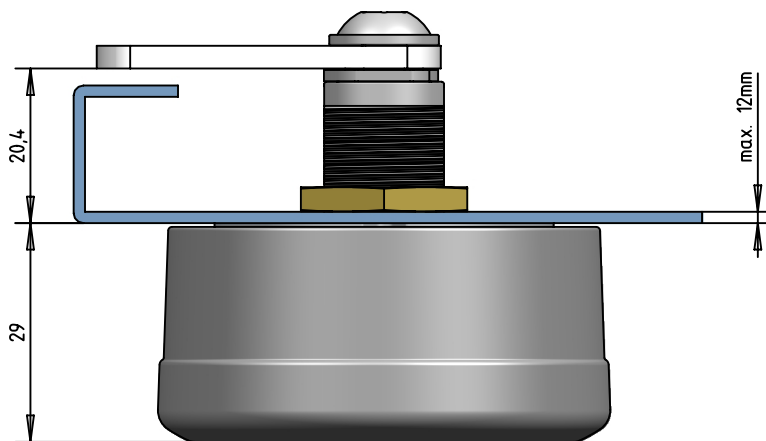

2. Fastening in wooden doors by means of cup drilling and optional anti-rotation bolt (Specify when ordering)

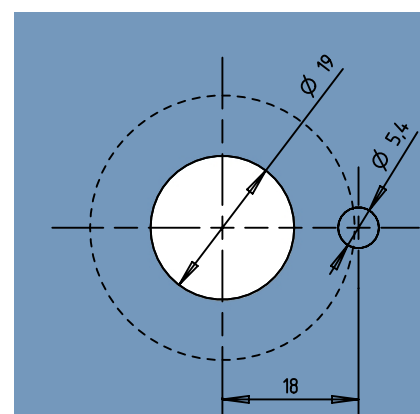
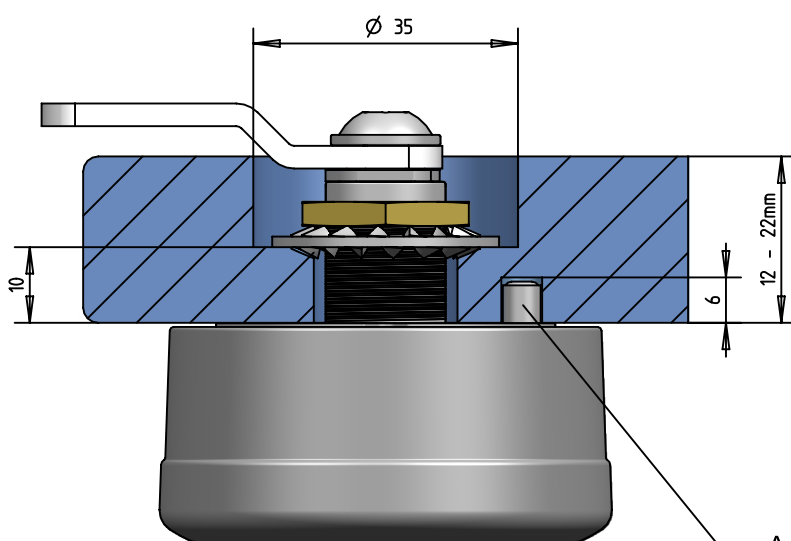

Anti-rotation bolt (optional)

Recessed mounting options

1. Recessed installation in steel doors using special perforations and an optional built-in-shell (Specify when ordering)

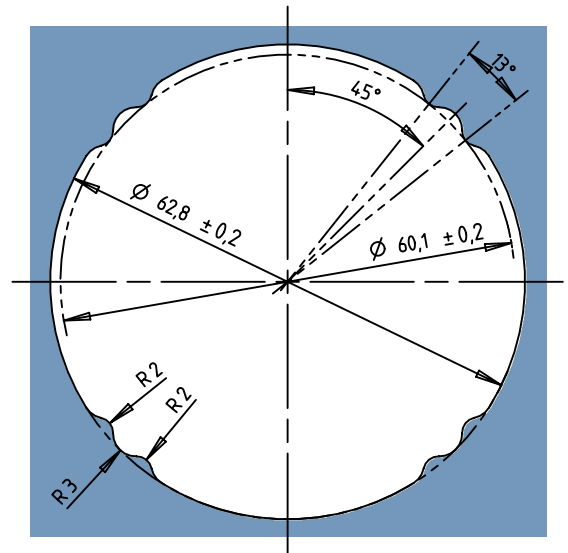
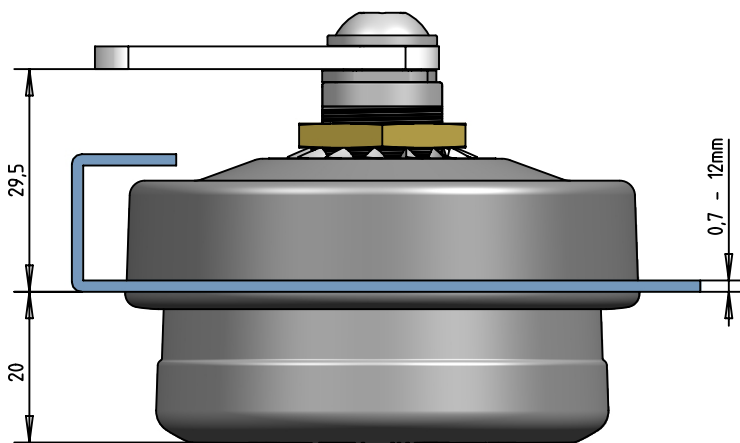

2. Recessed installation in wooden doors using special milling and optional installation shell (Specify when ordering)

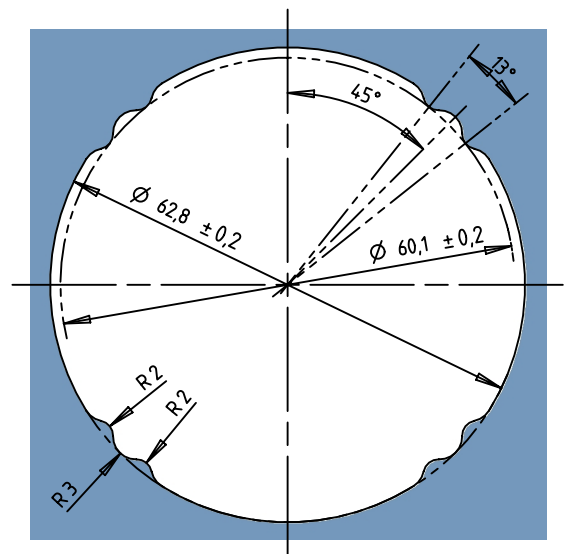
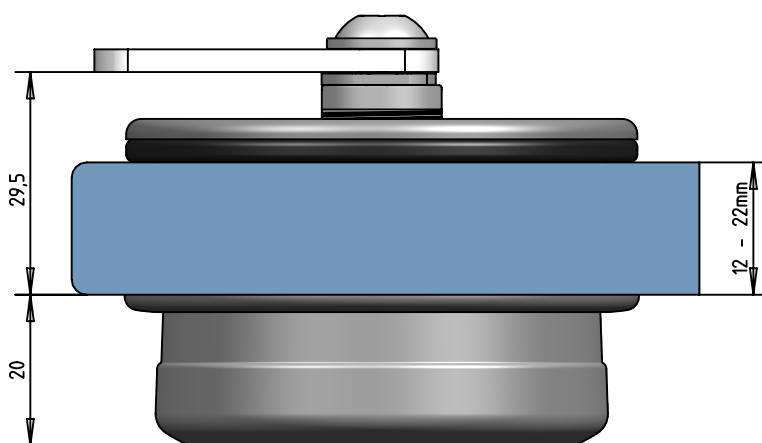

Assembly

1. Standard assembly with pre-assembled cam with 16x19 hole

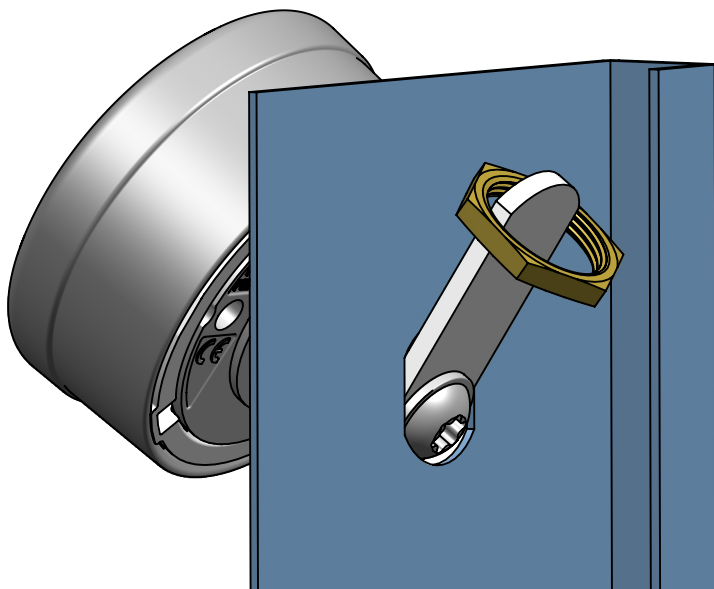

2. Assembly sequence for cams to be retrofitted

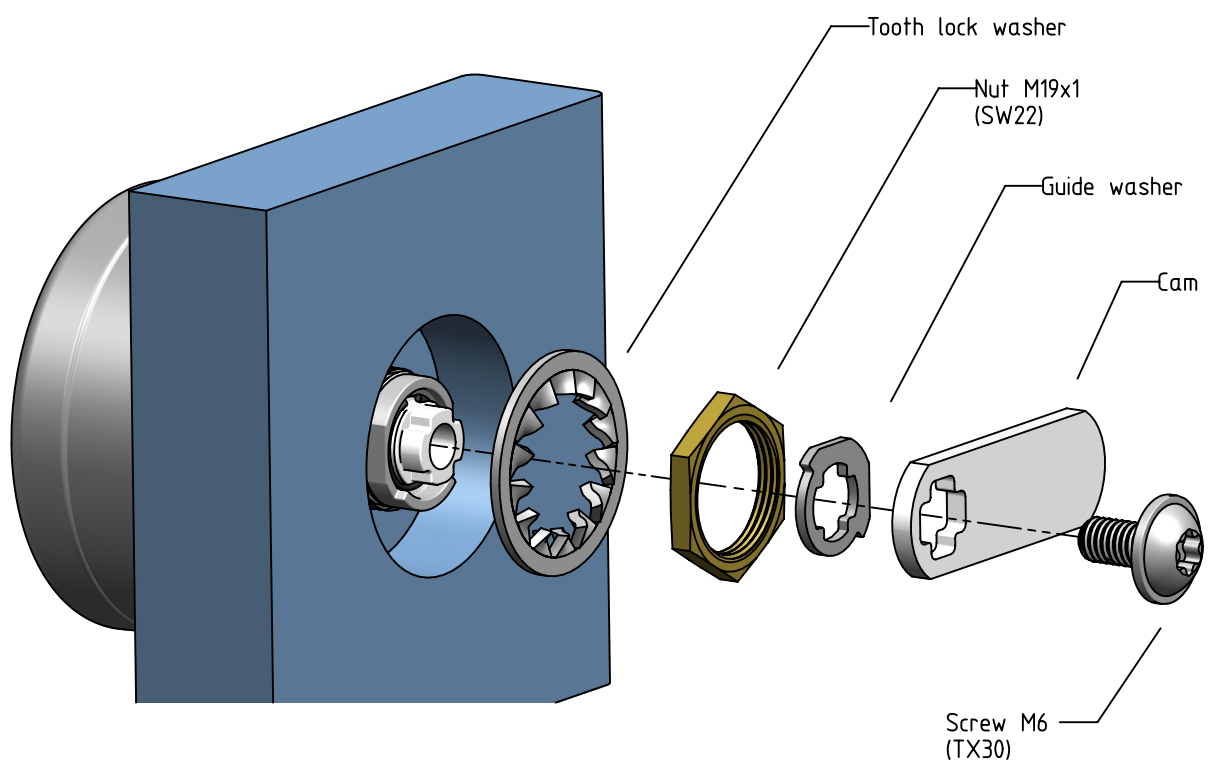

Set the direction of rotation

(Only required for subsequent cam installation)

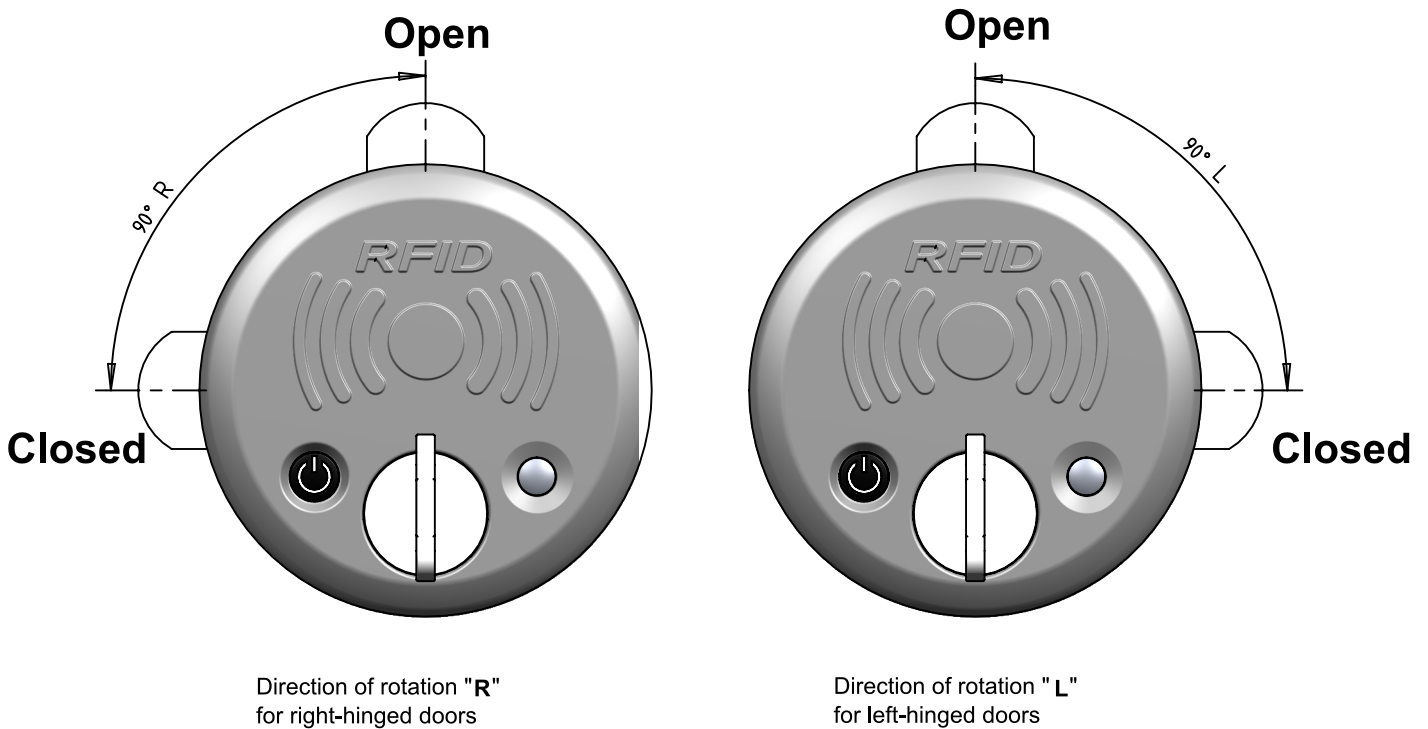
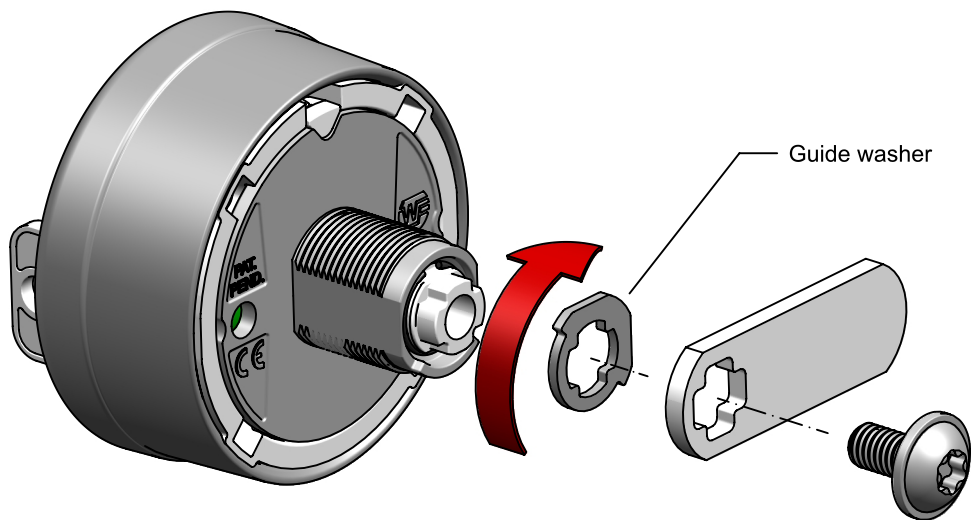

Battery change

Battery type: 1.5V AA alkaline
We recommend using brand name batteries

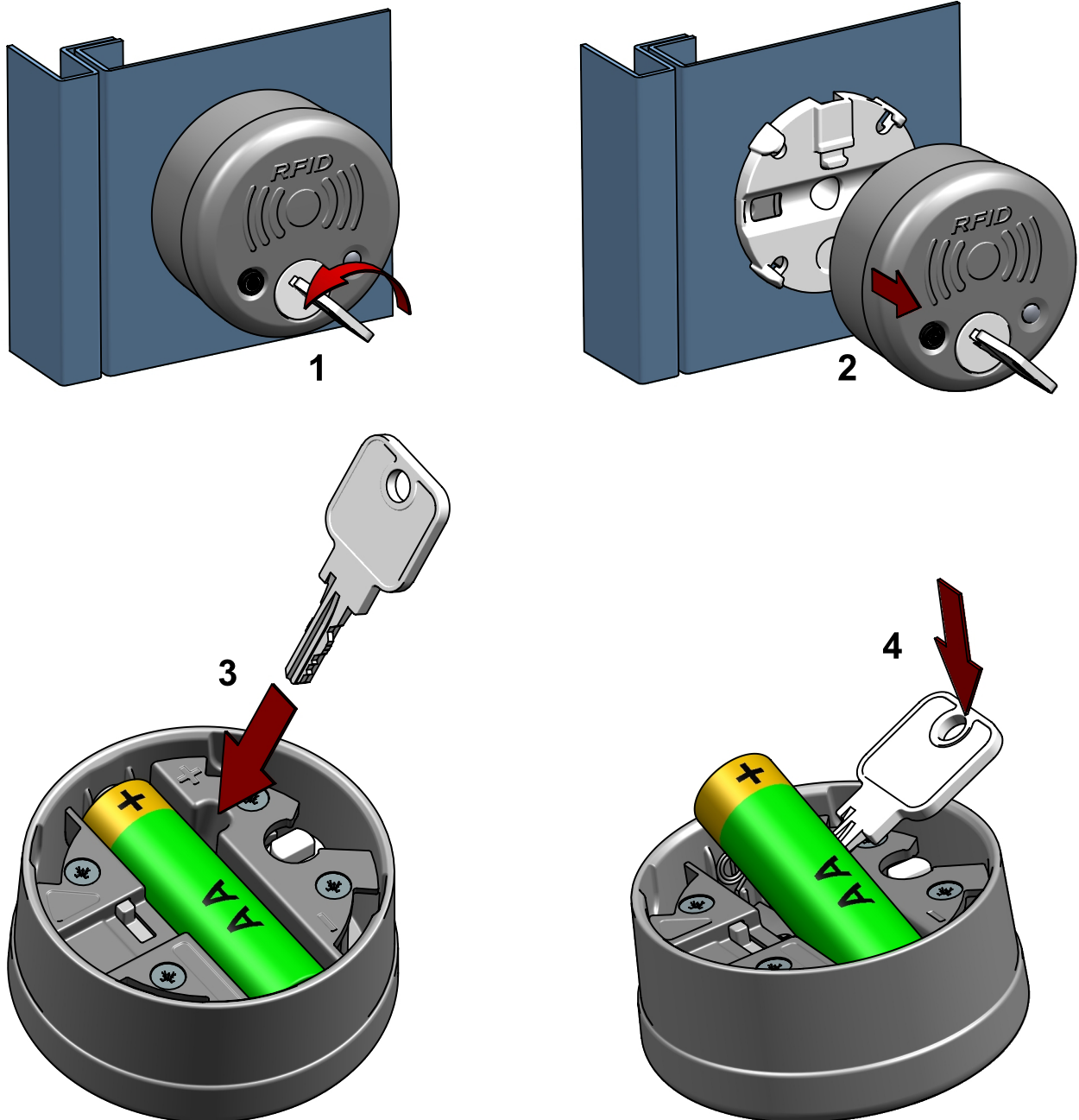

Attention:
Make sure the polarity is correct when inserting the battery!
Batteries inserted the wrong way round can damage the electronics
or destroy them.

Electronic devices and batteries may not be disposed of with
household waste!



Emergency opening using the service key

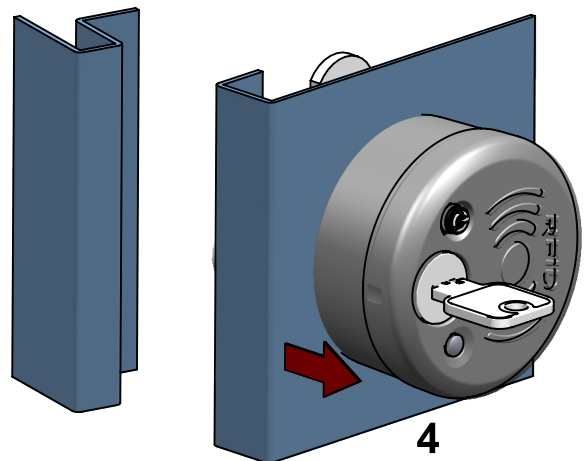
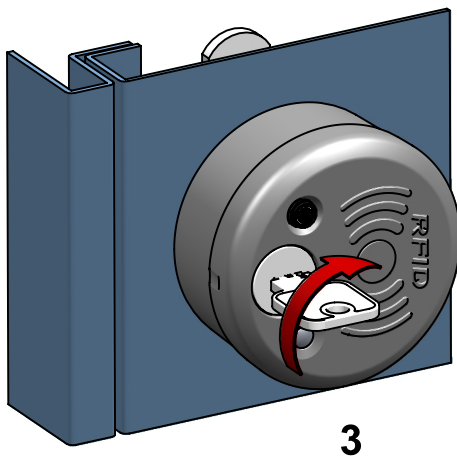
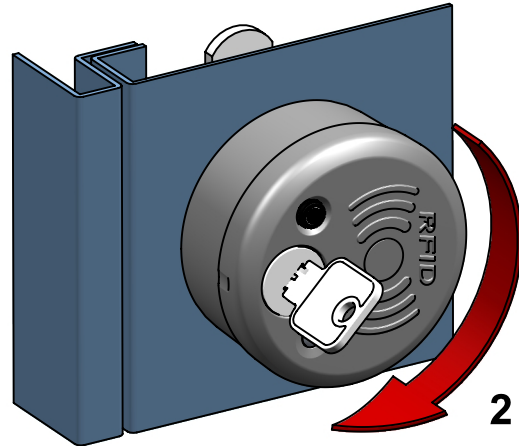
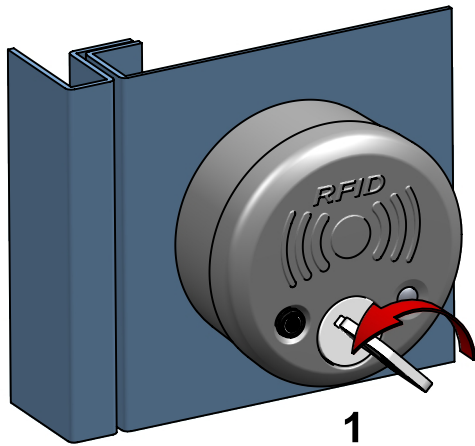

Order matrix cam

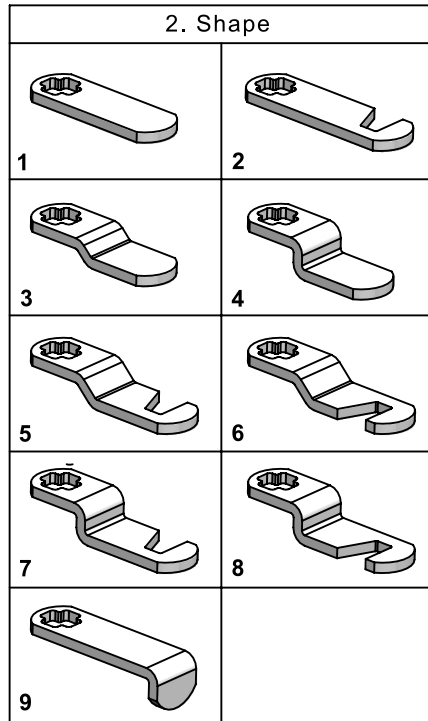
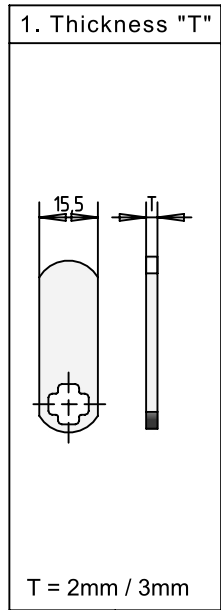

3. Crank high "A"

A	mm	for shape
00	0	-1-2-
03	1,2	-3-5-6-
04	1,6	-3-5-6-
05	2,0	-3-5-6-
06	2,4	-3-5-6-
07	2,8	-3-5-6-
08	3,2	-3-5-6-
10	4,0	-3-5-6-
12	4,8	-3-4-5-6-7-8-
14	5,6	-3-4-5-6-7-8-
16	6,4	-4-7-8-9-
20	7,9	-4-7-8-9-
21	8,3	-3-5-6-
25	9,9	-3-4-5-6-7-8-9-
28	11,1	-4-7-8-9-
32	12,7	-3-4-5-6-7-8-9-
34	13,5	-4-7-8-9-
38	15,0	-4-7-8-9-
40	15,9	-4-7-8-9-
44	17,5	-4-7-8-9-
48	19,1	-4-7-8-9-
50	19,9	-4-7-8-9-
64	25,4	-4-7-8-9-
72	28,6	-4-7-8-9-

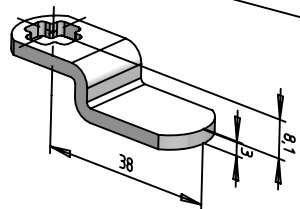
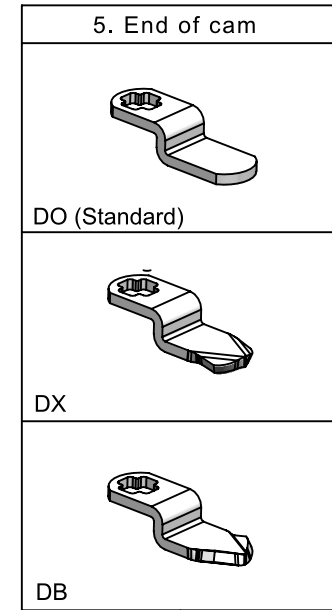
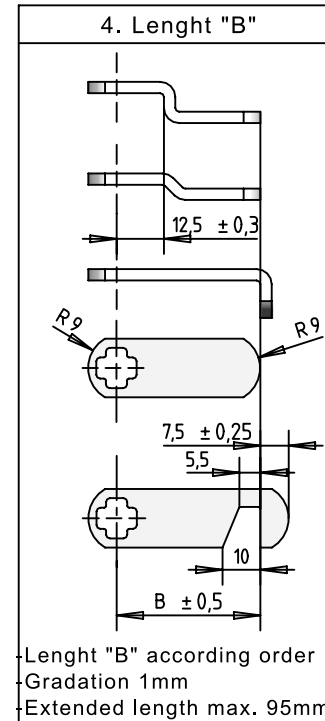

Order example cam:

C1905-3-4-20-38-DO

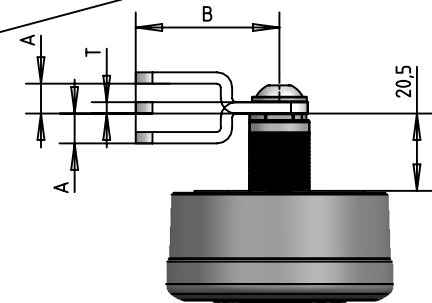

Order matrix lock / key / transponder

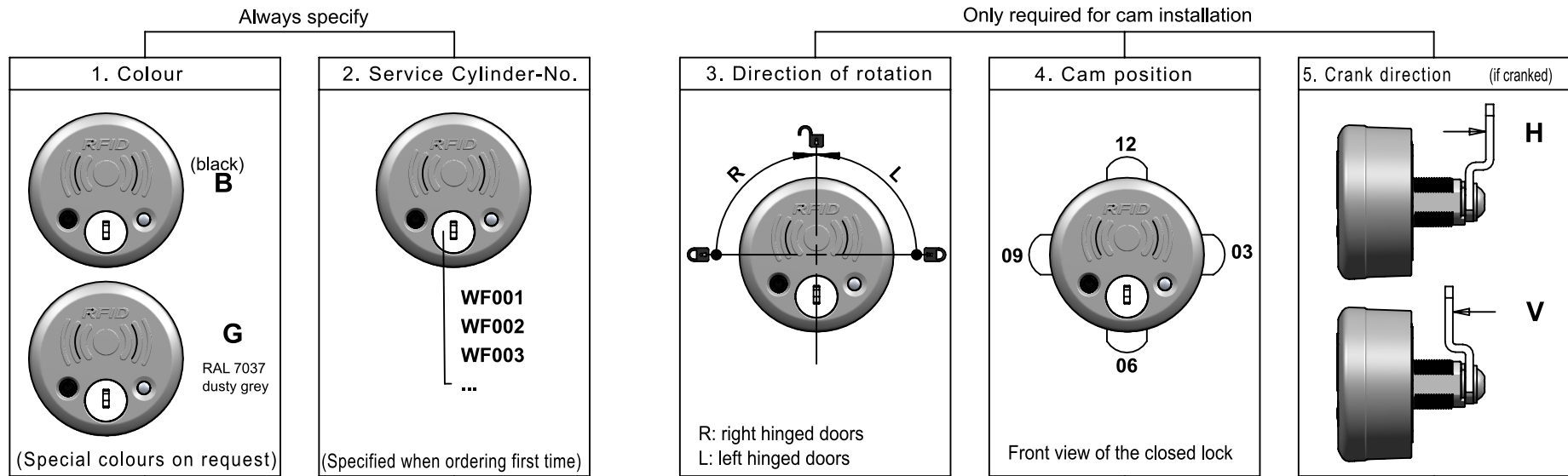

Order example lock:
(grey with mounted cam)

L1905-G-001 - R-09-H

(Riegel siehe 5.2)



Order example service key:
(matching the lock above)

S1905-001



Order example transponder:
(Special colors / printing on request)

T1905-KA

KA

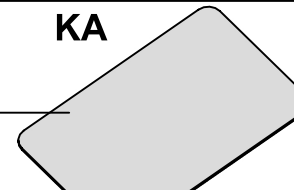

NFC-Card 85x54x0,9mm
PVC white

AN



NFC tags 40x32x4mm
ABS black

AB



NFC wristband 15mm wide,
adjustable, silicone black



Operating and programming instructions

RFID-Lock 1905

General information:

In order to keep energy consumption as low as possible, the locks are generally in sleep mode and must first be woken up using the ON button for each interaction.

After pressing the ON button, a compatible transponder must be presented within 5 seconds. If the interruption lasts longer than 5 seconds, the lock is automatically reset to sleep mode. This is indicated by the red LED with a long beep.

The RFID lock 1905 only works with the transponders issued, certified and initialized by W&F-LOCKS. (13.56 MHz, MIFARE Ultralight)

The public area of the transponder can be read and written by using an NFC-capable smartphone and a free app.

Using a master code and a command sequence, master transponders can be created with which emergency openings and / or settings can be made on the lock.

With the appropriate setting, information that is written to the transponder when a lock is closed can be read out using a smartphone. (e.g. locker number).

Successfully recognized transponders or commands are acknowledged by a short 3-fold green flashing with a deep beep, unrecognized transponders or commands by a short 3-fold red flashing with a high beep.

Select the operating mode suitable for your application:

Privat-Modus for applications with dedicated lockers

- The lock only accepts the previously trained transponders.
- Each transponder can be taught to any number of locks
- Up to eight transponders can be taught in per lock.

Privat-Modus-A: Transponder only for unlocking, automatic locking after 4 seconds.

Privat-Modus-B: Transponder for unlocking and locking.

Public-Modus for applications with free choice of lockers.

- The lock accepts any user transponder to close it.
- For opening, the lock only accepts the user transponder used for closing.
- Only one lock can be locked per user transponder at a time.
- After an emergency opening with subsequent relocking using a master transponder or service key the last saved user transponder remains authorized to open.
- Occupied display in the locked state by flashing red LED every 3 seconds.
- Auto-open timer adjustable.

Examples:

000 = no AUTO-OPEN

060 = AUTO-OPEN after 1 hour

999 = AUTO-OPEN after 16 hours 39 minutes (max.)

Tolerance: $\pm 10\%$

Master commands RFID lock 1905

An NFC-capable smartphone and an NFC app such as the free “**NFC Tools**” are required to write master command sequences to a transponder.

All master command sequences begin with the master code
 Factory setting master code: ***** (see delivery note)
 Factory setting operating mode: **Private-A**

Safety instructions:

Replace the factory master code with your own as soon as possible!
 Keep the number of master transponders as limited as possible!
 Label your own master transponders on the outside!

Master transponders that are no longer required can be formatted and reused as user transponders.

No spaces are allowed in the command sequences.
 Upper and lower case is not relevant.

Sequence	Function	Hints
(Master-Code) A	Opens or closes the lock	Valid for all modes
(Master-Code) L	Starts and ends the learning sequence for user transponders *	Only for private modes for max. eight user cards per lock
(Master-Code) B	Displays the battery status	<ul style="list-style-type: none"> •• = State of charge over 70% • = state of charge 30-70% •• = state of charge below 30%

* Teach-in of user transponders in the following order:

1. Presentation of the master transponder with sequence (master code) L
2. Present up to eight user transponders one after the other
3. Final presentation of the master transponder

Sequence	Configuration change	Hints
(Master-Code) M (New Master-Code)	Changes the master code	Master code always 6 digits
(Master-Code) U (Auto-Open-Timer)	Sets the public mode	Timer always 3 digits
(Master-Code) RA	Sets the private mode - A	Lock locks automatically (factory setting)
(Master-Code) RB	Sets the private mode - B	Lock locked with transponder
(Master-Code) T0	Turns off the beep	
(Master-Code) T1	Sets the beep	factory setting
(Master-Code) : Text / Nr.+ :	Sets the locker number *	The lock writes the locker number on the transponder when it is closed. (e.g. locker 001)
Remove the battery and wait about a minute. Then reinsert the battery with the ON button pressed.		Restores the factory settings. Deletes all programmed transponders.

* a "+" sign after a number can be used to automatically increment the corresponding number with each transponder presentation.

To change the configuration, sequences can be lined up in order to change several settings at the same time. The introductory master code may only appear once. The entire sequence can consist of a maximum of 31 characters.

Example command sequence: 123456M113355U000: Locker 001+:

The old master code 123456 is changed to 113355, the public mode without auto-open timer and the locker name “locker 001” are set.

The + sign automatically changes the command sequence of the transponder to 123456M113355U000: Locker 002+, so that the next lock to which the transponder is presented receives the same settings except for the locker name, which counts up by one to "Locker 002".